



深圳飞特模型有限公司

SHENZHEN FEETECH RC MODEL CO.,LTD.

产品规格书 PRODUCT SPECIFICATION

客 户 (CUSTOMER) :
型 号 (MODEL) : FT9200BL
名 称 (PRODUCT NAME): 12V 200kg. cm数码180度铝中壳钢齿轮无刷舵机
版 本 (EDITION) : A/0

在您下单采购本产品之前, 请阅读本规格书并在下列确认栏内签字回传。

Sign back before you place an order to purchase this product,
please read this specification and in the following admit column.

飞特确认/ FEETECH APPROVED

编写 EDIT	审核 CHECKED	确认 APPROVED
丘俊威	颜永杰	

客户确认/CUSTOMER APPROVED

审阅 REVIEW	审核 CHECKED	确认 APPROVED

地址: 广东省深圳市龙岗区横岗镇六约埔厦路60号2楼

ADD: Floor 2, No 60, PuXia Road, LiuYueHengGang Town, Long Gang District,
ShenZhen, 518173, China

电话/Tel: 0755-89335266 网址/Website: www.feetech.cn

		深圳飞特模型有限公司 SHENZHEN FEETECH RC MODEL CO., LTD.		版本EDITION: A/0
型号/MODEL: FT9200BL		产品规格书 PRODUCT SPECIFICATION		日期/Date: 2024-11-26
页 码 Page: 3/7				
1. 使用环境条件 Apply Environmental Condition:				
No.	项目 (Item)		规格 (Specification)	
1-1	保存温度Storage Temperature Range		-30℃~80℃	
1-2	运行温度Operating Temperature Range		-40℃~60℃	
2. 测试环境 Standard Test Environment:				
No.	项目 (Item)		规格 (Specification)	
2-1	温度 Temperature Range		25℃ ±5℃	
2-2	湿度 Humidity Range		65%±10%	
3. 安全特性与认证 Secure Performance and Certificate				
No.	项目/Item	认证Certificate	备注 (remarks)	
3-1	ASTM F963	No	美国玩具检测标准	
3-2	EN71	No	欧盟市场玩具类产品的规范标准	
3-3	FCC	No	对电子、电器中的电磁干扰，管理和控制无线电频率范围，保护电信网络、电器产品的正常工作。	
3-4	ROHS	Yes	电子，电器设备中对人体有害物质的含量。	
3-5	REACH	NO	欧盟法规《化学品的注册、评估、授权和限制》	
4. 外观检查 Appearance Inspection:				
No.	项目 (Item)		规格 (Specification)	
4-1	外观尺寸OutlineDrawing		尺寸见附件(第12项) See the appendix	
4-2	外观Appearance		无损坏，不允许影响功能 No damage and mustn't affect functions.	
5. 电气特性 Electrical Specification				
No.	项目 (Item)	规格 (Specification)	规格 (Specification)	备注 Remark
5-1	工作电压范围 Working Voltage Range	9V-12.6V		
5-2	典型工作电压 Operating Voltage	12V		
5-3	空载速度±10% No Load Speed	0.25sec/60° (40RPM)		
5-4	空载电流±10% Running Current (no load)	320mA		
5-5	堵转扭力 Stall Torque (at locked)	200kg. cm		
		2782oz. in		
5-6	堵转电流±10% Stall Current (at locked)	10.2A		
5-7	静态电流±10% Idle Current (at stopped)	40mA		
5-8	额定负载 Rated Torgue	66.6kg. cm		
5-9	额定电流 Rated Current	3400mA		
5-10	Kt常数	19.6kg. cm/A		

		深圳飞特模型有限公司 SHENZHEN FEETECH RC MODEL CO., LTD.		版本EDITION: A/0	
型号/MODEL: FT9200BL		产品规格书 PRODUCT SPECIFICATION		日期/Date: 2024-11-26	
页 码 Page: 4/7					
6 机械规格 Mechanical Specification:					
No.	项目 (Item)	规格 (Specification)		备注 (remarks)	
6-1	外观尺寸 Size	65X30X48		见图纸See drawings	
6-2	机构极限角度 Limit Angle	No limit			
6-3	外壳材质 Case material	Aluminum			
6-4	齿轮材质 Gear material	钢 Steel			
6-5	轴承类型 Bearing type	滚珠轴承 Ball bearings			
6-6	角度传感器 Angle Sensor	类型Type	12Bits Magnetic Coding		
6-7	连接器和电缆 Connector and Cable	类型 Type	XT30+JR		
		Material材质	PVC		
		线长度 Length	47±2CM		
		引脚定义 Pin Definition	1		Signal
			2		VCC (5V)
3	GND				
4	GND				
5	VCC (12V)				
6-8	重量The Weight	250g± 5g			
6-9	出力轴 Horn Type	15T/7.6mm			
6-10	减速比Gear Ratio	1/399			
6-11	齿轮虚位Back Lash	≤0.5°			
6-12	出力轴螺丝 The rocker screw	M3X6			
6-13	马达Motor	Brushless Motor			
7 控制特性Control Specification:					
No.	项目 (Item)	规格 (Specification)		备注 (remarks)	
7-1	控制信号 Command Signal	Pulse width modulation			
7-2	控制系统类型 Control System Type	Digital comparator			
7-3	操作角度 Operating Travel	180±5° (at 500→2500 μ sec)			
7-4	两边角度差 Left&Right Travelling Angledeviation	≤ 5°			
7-5	回中差 Centering Deviation	≤1°			
7-6	中立位置 Neutral Position	1500 μ sec			
7-7	死区宽度 Dead Band Width	≤4 μ sec			
7-8	旋转方向 Rotating Direction	逆时针 Counterclockwise (在500→2500 μ sec)			
7-9	脉波宽度范围 Pulse Width Range	500→2500 μ sec			
7-10	电子保护 Electronic Protection	堵转8秒/Stall 8sec		舵机堵转后, 输出扭矩超过过载扭矩并持续超过8S后自动输出保护扭矩, 可修改过载扭矩, 保护时间及保护扭矩	



深圳飞特模型有限公司
SHENZHEN FEETECH RC MODEL CO., LTD.

版本EDITION:
A/0

型号/MODEL:
FT9200BL

产品规格书
PRODUCT SPECIFICATION

日期/Date:
2024-11-26

页 码 Page: 5/7

8 可靠性测试 Reliability Testing

No.	项目 (Item)	规格 (Specification)	备注 (remarks)
8-1	负载寿命测试Life test	>200000次	正转60度0.25S, 停0.5S, 反转60度0.25S, 停0.5S为一次, 持续循环工作, 负载1/5堵转扭矩1/2的空载速度 测试工作电压12V
8-2	马达噪音The motor noises	50±5dB	环境噪音40-45 dB 距离噪音仪30cm处测试
8-3	舵机噪音Steering gear noises	70±5dB	环境噪音40-45 dB 距离噪音仪30cm处测试-1/3空载速度-12V
8-4	防水性能Waterproof performance	IP66	

9 外观尺寸 Outside Dimension(单位Unit: mm)

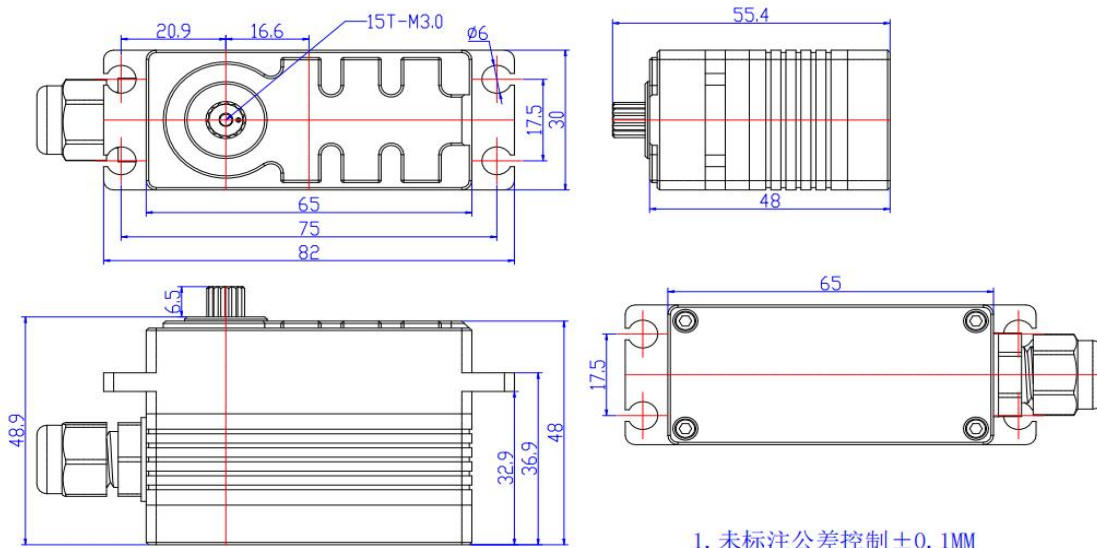



深圳飞特模型有限公司
SHENZHEN FEETECH RC MODEL CO., LTD.

版本EDITION:
A/0

型号/MODEL:
FT9200BL

产品规格书
PRODUCT SPECIFICATION

日期/Date:
2024-11-26

页 码 Page: 6/7

10 配件 Accessories



11 12V运动特性图 Performance

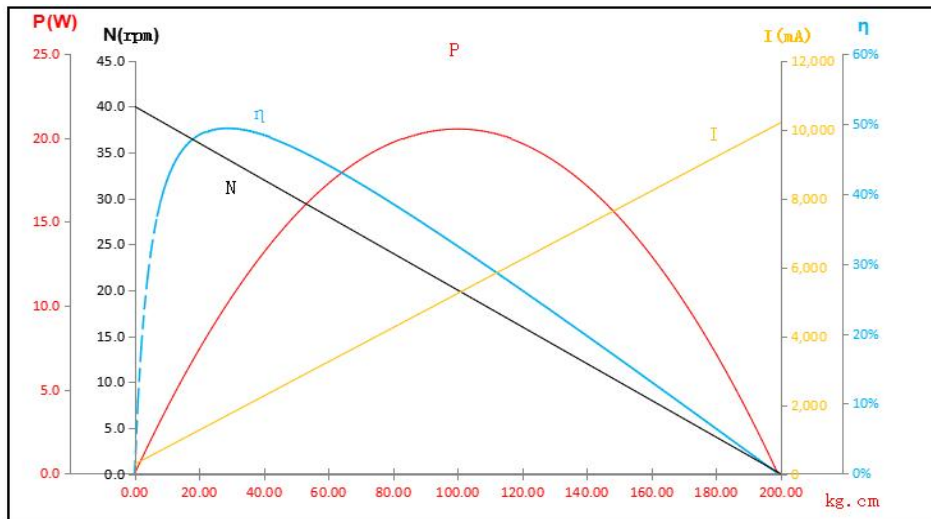



深圳飞特模型有限公司
SHENZHEN FEETECH RC MODEL CO., LTD.

版本EDITION:
A/0

型号/MODEL:
FT9200BL

产品规格书
PRODUCT SPECIFICATION

日期/Date:
2024-11-26

页 码 Page: 7/7

12 接口定义 Interface Definition

控制信号参数 (Control signal parameter)

信号周期 Signal Period	20ms	
脉冲宽度 Pulse Width	500us-2500us	
信号高电平电压 Signal high Voltage	2V-5V	
信号低电平电压 Signal Low Voltage	0.0V-0.45V	

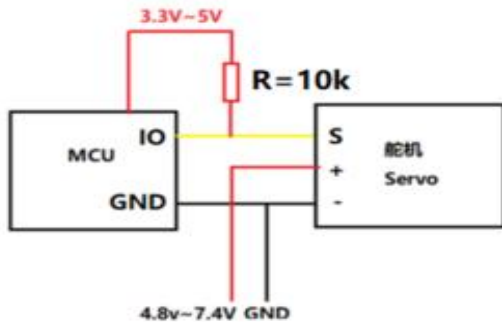

13 包装出货简图 The Packaging Detail

